

# WHHR125DC

SAP Q Eligible

## WHOLE HOUSE HEAT RECOVERY UNIT



### FEATURES

- Highly efficient, low energy solution to condensation and pollutant control
- Continuous ventilation in kitchen plus up to 5 additional wet rooms
- Over 90% heat exchange efficiency
- Low noise levels
- Building Regulations Part L and Part F compliant

### GENERAL

- SAP Q eligible whole house heat recovery unit for homes
- continuous ventilation in kitchen and up to 5 additional wet rooms - optimum use in kitchen plus 2 wetrooms
- maximum airflow 165m<sup>3</sup>/hr
- suitable for areas up to 115m<sup>2</sup>
- up to 91% of heat is recovered from air extracted from warm, moist rooms to create a stable, comfortable, healthy environment
- easy to install with quick fix mounting bracket
- for fitting into lofts, false ceilings or cupboards
- multiple choice low (trickle) speed and boost options
- boost speed obtainable by user via remote switch/pull cord (ie a volt free contact switch - not supplied) or by a humidistat, thermostat, or PIR sensor using an intermediate, external relay (available separately)
- has integral over-run timer for boost speed
- frost protection
- low noise levels
- low running costs
- gives extra security by removing need to open windows
- guaranteed for 3 years
- Vectaire Ltd can supply all accessories for use with these units, including ducting and metal filters, outside grilles and wall cowl

### SPECIFICATION

- very compact, low profile unit
- housing from Zintec sheet steel powder coated white
- expanded polypropylene (EPP) heat exchanger
- closed cell foamed Nitrile rubber insulation - class "O" fire rating
- grade G3 synthetic filters, flame resistant to BS5588
- can be used with 100mm or 125mm dia ducting without needing adaptors
- operates in temperature up to 40°C
- weight - 16kg

### COMPLIES WITH

- Part L of Building Regulations for enhanced energy saving capability
- Part F of Building Regulations for reliable, efficient ventilation
- EU RoHS Directive Compliant.
- Conforms to requirements of EC Council directives relating to Electromagnetic Compatibility and Electrical Safety: 2006/95/EC (LVD), 2004/108/EC (EMC)EN 60335-1:2002/A2:2006, EN 60335-2-80:2003/A1:2004.
- CE marked
- SAP Q eligible
- EST Best Practice Compliant



### LOFT OR WALL INSTALLATION

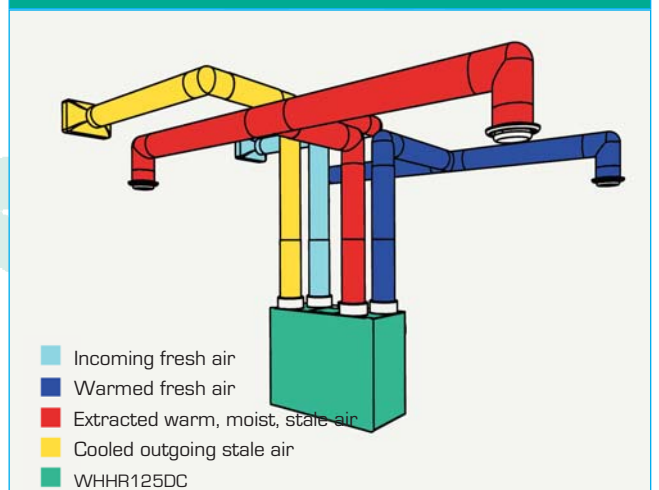

# WHHR125DC - TECHNICAL INFORMATION

## ENERGY LEVEL PERFORMANCE - using rigid ducting

Exhaust Terminal Configuration	Fan Speed Setting	Specific Fan Power (W/l/s)	Heat Exchange Efficiency (%)	Energy Saving Trust Best Practice Performance Compliant
Kitchen + 1 additional wet room	100% variable	0.70	91	yes
Kitchen + 2 additional wet rooms	100% variable	0.70	89	yes
Kitchen + 3 additional wet rooms	100% variable	0.72	89	yes
Kitchen + 4 additional wet rooms	100% variable	0.90	88	yes
Kitchen + 5 additional wet rooms	100% variable	0.99	87	yes

Figures from BRE test results

## PERFORMANCE

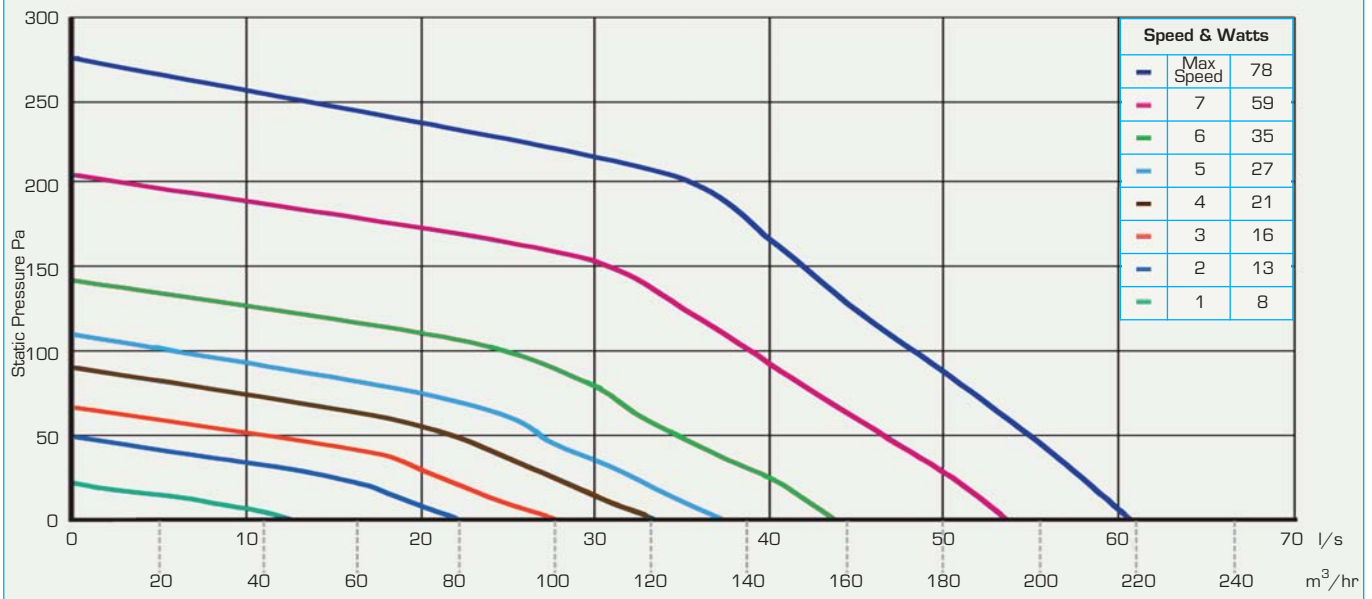

## DIMENSIONS - mm

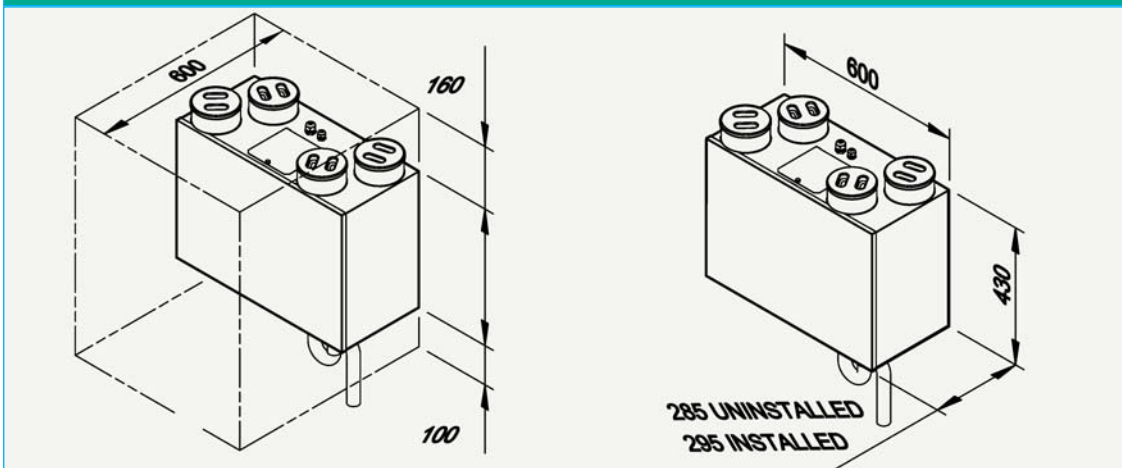

### Vectaire Ltd

Lincoln Road  
Cressex Business Park  
High Wycombe  
Buckinghamshire  
HP12 3RH

Tel: +44(0)1494 522333

Fax: +44(0)1494 522337

Email: sales@vectaire.co.uk

Web: www.vectaire.co.uk



# "WHHR125DC" Whole House Heat Recovery Unit with Low Energy DC Motor

*Installation, Operating and Maintenance  
Instructions - domestic and commercial use*



It is important to read this Instruction Manual carefully before installing or using the product. Following these instructions will ensure that your ventilation system is installed, commissioned and used properly and continues to operate effectively



## Contents

<b>Section</b>	<b>Page Number</b>
Introduction	3
How the system works - Features	4
Installation	
- Safety & Guidance	5
- Dimensions	5
- Pre-installation inspection	6
- Mounting	6, 7
- Drain assembly	8
- Ducting	9
- Electrical connections	10
- Wiring diagram	10
Commissioning	
- Quick commissioning mode	11
- Full commissioning mode for optimum efficiency	12
- Boost speed setting	13
- Resetting the controller	13
Service and Maintenance	14
- Cleaning	15
- Filter replacement	15
Service record	16



## Introduction

Interior comfort, air quality and energy efficiency are vitally important considerations in buildings today. Controlled ventilation is even more vital in virtually airtight modern homes.

The Vectaire WHHR125DC has been developed to meet these demands by providing clean fresh air whilst extracting stale polluted air from the building using state of the art technology to maximise energy efficiency.

### **For the home owner or occupant, this Instruction Manual explains:**

- How your Vectaire WHHR125DC system works.
- How to operate and maintain your Vectaire WHHR125DC.

### **For the professional installer, this Instruction Manual explains:**

- How to install the Vectaire WHHR125DC.
- How to commission the unit.
- How to maintain the unit.

### **Safety Notice**

**It is important to read this Instruction Manual carefully before installing or using the product. Following these instructions will ensure that your ventilation system is installed, commissioned and used properly and with the correct maintenance procedures continues to operate effectively. Vectaire will not be held responsible and will not accept liability for any damage caused to persons or property through failure to follow the guidance provided in this manual. It should always be available with the product for easy reference.**

**This unit SHOULD NOT be switched off. It is designed to run continuously. If it is switched off indoor pollutant and moisture levels may increase.**

## How the system works

The Vectaire WHHR125DC works by extracting stale polluted air from rooms where most moisture is generated and providing fresh pre-warmed air taken from outside the house and delivering it to other rooms, creating a flow of fresh, clean air throughout the house.

Most of the heat reclaimed from the extracted air is used to pre-heat incoming fresh air by means of a "heat exchanger" built into the unit. The ventilation system operates continuously so the air remains free from harmful pollutants and excessive moisture, but without wasting heat or energy unnecessarily.

The unit is usually installed in a roof space or cupboard and the air travels from terminals built into the ceiling which are connected by hidden ducts to the unit. These ceiling terminals should not be disturbed or adjusted - they have been set at installation to give the correct amount of ventilation to the property.

Each unit is commissioned individually so the amount of air moved is set to suit the specific size and style of the house. Most systems will also have a facility to boost the extraction rate at times when more moisture is being generated, such as when bathing or cooking.

During cold weather the frost protection programme will automatically vary the ventilation to ensure there is no build up of ice in the unit. There is an optional summer mode override switch which enables the unit to operate on extract only mode (ie there is no incoming air). If the unit is operating this way and the building is occupied, it is advisable to open either windows or trickle ventilators to ensure a proper balance of air. (Windows and ventilators should NOT be open when operating as a heat recovery unit).

There may be small changes in airflow or noise levels. This is quite normal - the unit is designed to operate in this way. The system will have been pre-set to run continuously to provide normal ventilation. If a boost switch has been installed, it can be used to increase the extract ventilation rate at times when moisture or pollutant levels are considered excessive. You may have electronic sensors which detect high levels of moisture and pollutants which boost the system automatically.

All whole house ventilation units require periodic maintenance and this must only be carried out by a suitably qualified and competent person. See the servicing and maintenance section for further details.

## Features of the Vectaire WHHR125DC

- Easy installation mounting bracket.
- Standard 15mm fitting for condensate drain connection.
- The duct ports accept 100 and 125mm diameter ducting.
- Quick commissioning with step-less fan speeds
- 3 speed options - Continuous, Boost and Setback
- Advanced frost protection control.
- The boost speed can be triggered by:
  - a remote switch/pull cord (a volt free contact switch) (not supplied)

**OR** by any of the following when used with an intermediate, external relay (available separately - please contact Vectaire Technical Dept for further information on the use of this):

- PIRFF (passive infra red)
- DRH240 (dynamic remote humidistat)
- THM (thermostat)
- a light switch (if more than one light switch is used, **each one must be a double pole switch**)
- Accurate system balancing through the independent adjustment of the supply and extract fans.
- Manual Summer Mode enables extract only mode thus reducing the supply of warmer outside air to the dwelling to maintain a cooler internal temperature.

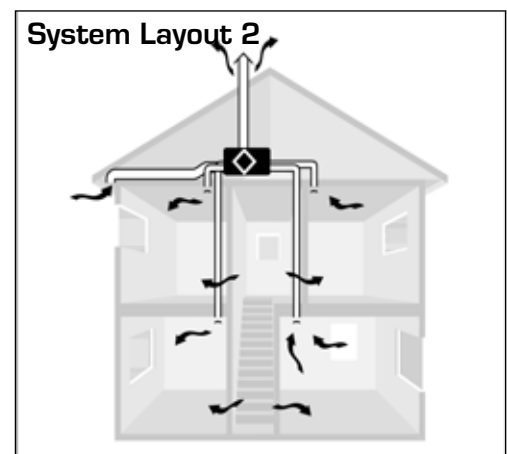
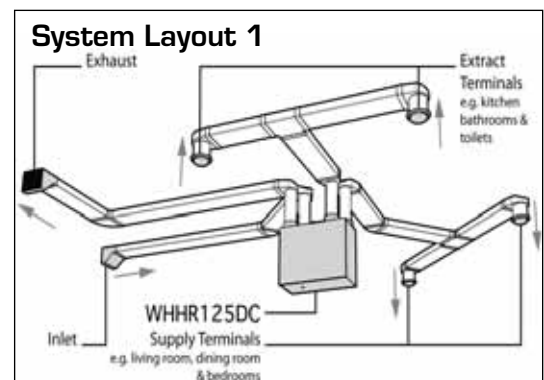

## Installation

### IMPORTANT: READ THESE INSTRUCTIONS FULLY BEFORE INSTALLING THIS APPLIANCE!

The Vectaire WHHR125DC is designed to be fitted into the roof space or a cupboard. These diagrams show the dimensions of the unit and the additional space required around the unit to allow for future servicing and maintenance.

The unit must **NOT** be installed in an area which does not have sufficient access for future maintenance.

The appliance must **NOT** be installed in an environment which contains:

- Excessive oil or a grease laden environment.
- Hazardous gases, liquids or vapours that are flammable or corrosive.
- Ambient temperatures above 40°C or below -5°C.
- Humidity levels above 90% or a wet environment.

### Safety and guidance

- The electrical installation of the appliance **MUST** be carried out by a suitably qualified, competent person and all wiring must be in accordance with current I.E.E. Regulations and all appropriate standards and applicable regulatory guidance.
- The appliance must be connected to a local isolation switch with a contact separation of at least 3mm.
- The appliance is suitable for 230V ~ 50/60Hz single phase with a fuse rating of 3A.
- The condensation drain **MUST** be fitted and insulated with the equivalent of at least 25mm of insulating material with a thermal conductivity of 0.04 W/(mK).
- Ensure that external grills are located away from any flue outlet, in accordance with all relevant Building Regulations.
- Always ensure ducting is free from blockages before switching the unit on as this may invalidate your guarantee.
- Precautions must be taken to avoid the back-flow of gases into the room from an open gas flue or other fuel-burning appliances.
- We recommend a minimum distance of 2m between the external air supply inlet and the extract air outlet to prevent cross contamination and a minimum distance of 200mm between the appliance and any sharp bends in duct work.
- The appliance is not suitable for installation to the exterior of the dwelling.

Installation of the appliance **MUST** be carried out by a qualified and suitably competent person and should be carried out in clean, dry conditions where dust and humidity are at minimal levels. It should only be installed after other building works have been completed and the building in which it is installed cleaned. Failure to comply with any of the above points will have an impact on the validity of the guarantee.

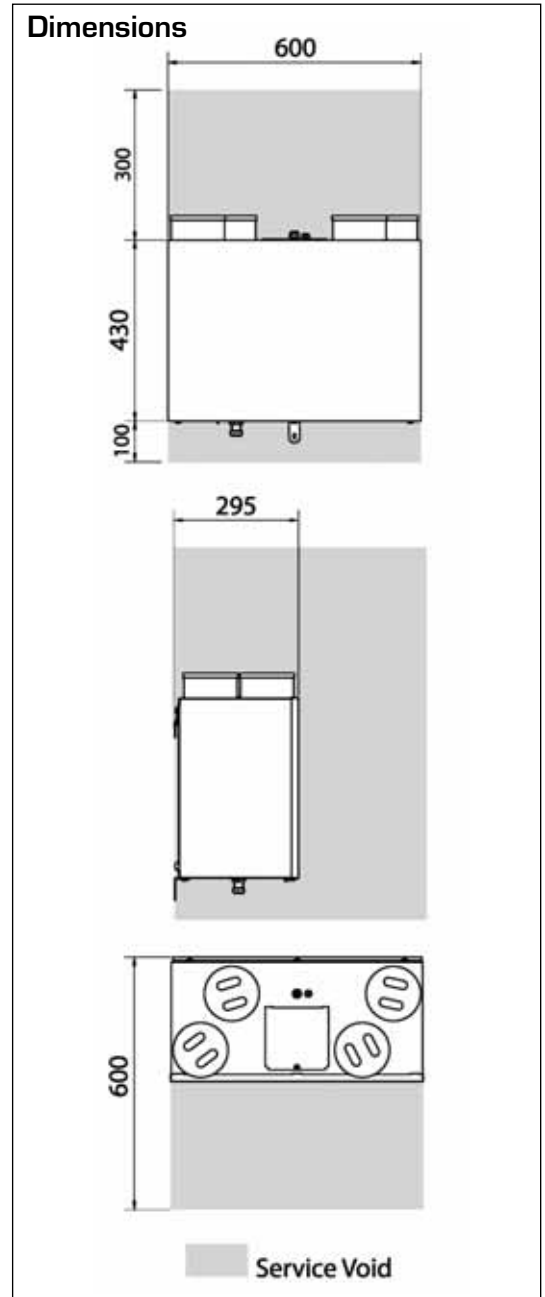

## Installation

### Transportation, packaging and storage prior to installation

- Great care should be taken when transporting the appliance, DO NOT drop as damage may occur within the appliance.
- The unit must always be stored in a clean, dry environment.
- Remove all packaging before installation.

### Pre-inspection

- Inspect the appliance and electrical supply cord for any damage.
- Check all accessories have been supplied.
- Inspect the appliance and supply cord for any damage. Any damage must be repaired by a suitably qualified and competent person.

### Parts list

- 1 x Vectaire WHHR125DC unit.
- 2 x Wall mounting brackets.
- 1 x Safety bracket.
- 1 x 15mm Drain connector.

4 x M6x10mm pan head screws.

4 x M6 washers.

Any parts shortages or faults must be reported to the supplier immediately.

### Installation - mounting

Do not remove the transport bungs until connecting ducting. Transport bungs are fitted to prevent debris falling into the unit and causing blockages and damage.

**The Unit Must be mounted Plumb/Level Front to Back and Side to Side.**

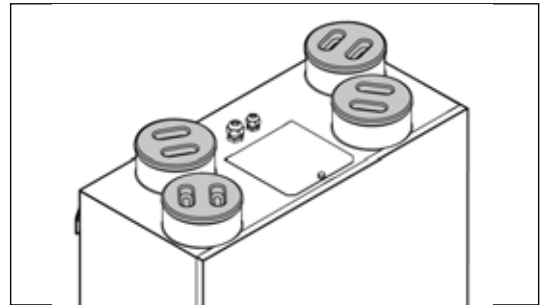

1. Mark a horizontal line on the wall using a spirit level. This line will be approximately 95mm below the location of the top face of the unit when fitted (excluding duct ports).

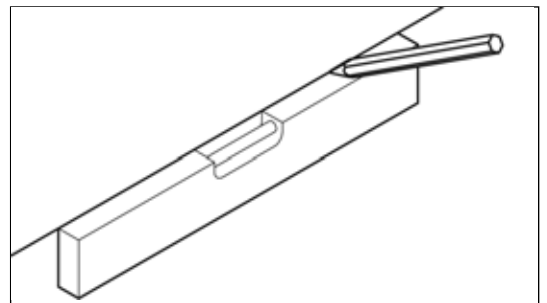

2. Use one of the mounting brackets as a template to mark the three fixing hole centres.
3. Drill holes for fixings, always use a fixing suited to the wall type.

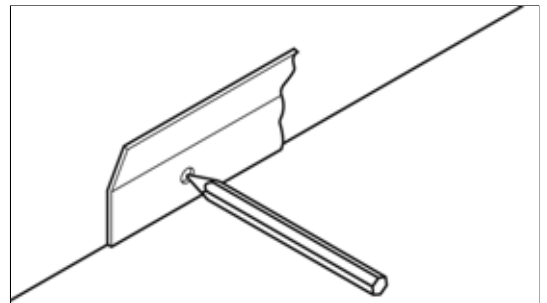

4. Mount one fixing bracket to the wall ensuring the interlocking side is at the top, as shown

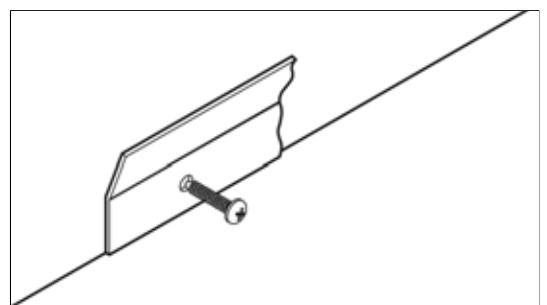

## Installation

5. Fix the remaining bracket to the unit using the M6 screws and washers provided, ensuring the interlock side is at the bottom. Do not overtighten.

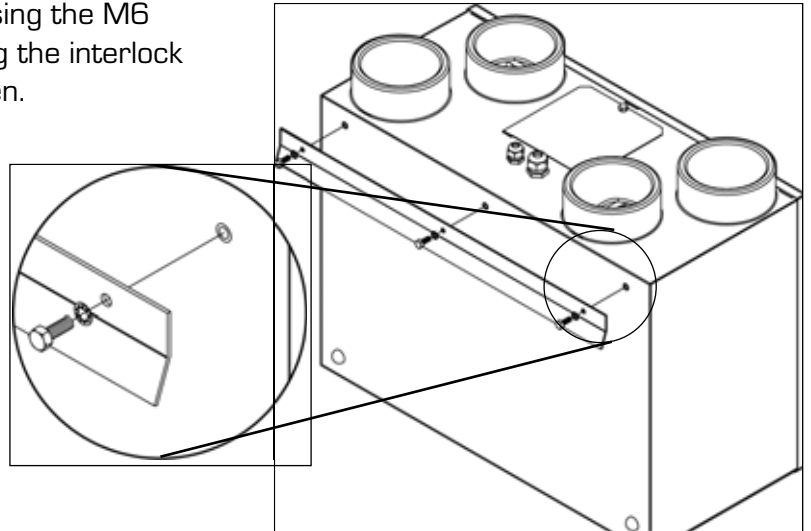

6. Mount the unit by locating the two mounting brackets together. Ensure a positive location is made between the two mounting brackets.

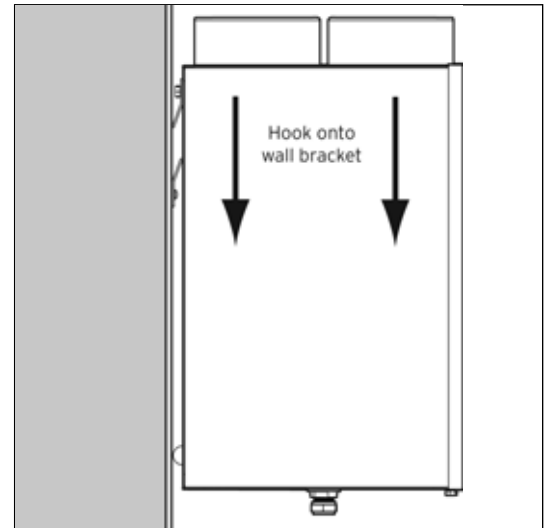

7. Fix the lower safety bracket as shown using the remaining M6 screw, washer and suitable wall fixing. Hook onto wall bracket.

This bracket **MUST** be fitted to secure the unit.

**Packing to be used as required behind the Safety Bracket to ensure Unit is level.**

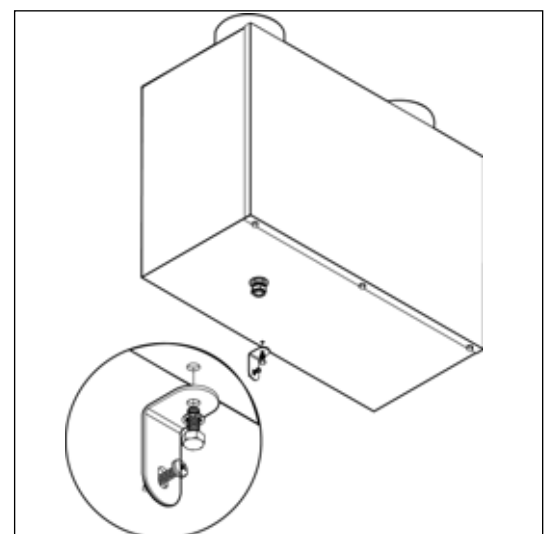

## Installation - Drain Assembly

A drain must be connected to allow condensation to be removed from the unit.

The drain connection is made via the 15mm connection on the base of the unit.

The drain must discharge into the household drainage system via a U-bend, which must act as an air lock.

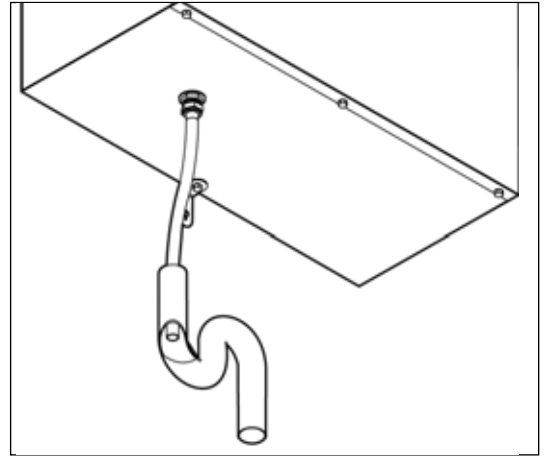

1. Attach a 15mm condensate pipe using a compression fitting (drain pipe shown uninsulated for clarity).

If any part of the Condensate drain is in an unheated space it **MUST** be insulated with the equivalent of at least 25mm of insulating material with a thermal conductivity of 0.04 W/(mK).



**IMPORTANT NOTE:** The drain must incorporate a U-bend to prevent air penetration.

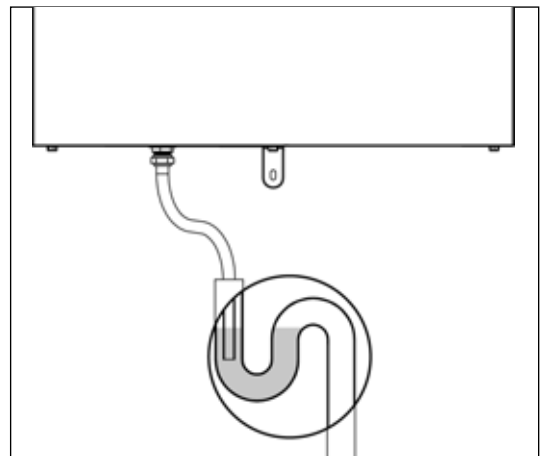

## Installation - Ducting

Transport bungs are fitted to prevent debris falling into the unit and causing damage. Premature removal of the transport bungs may invalidate the guarantee.

1. When the ducting has been installed and you are ready to connect the unit, remove the transport bungs from the duct ports. (This should be **AFTER** the premises has been cleaned).
2. 125mm ducting fits to the outer of the duct ports as shown.
3. 100mm ducting fits to the inner of the duct ports as shown.

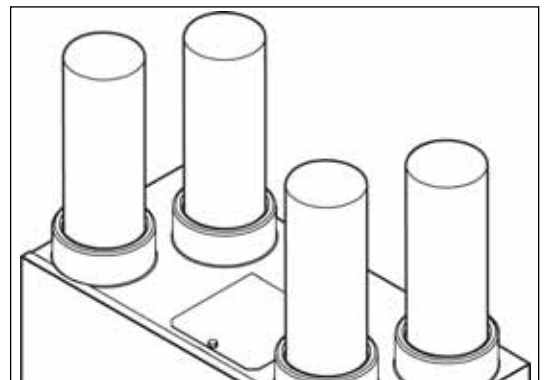
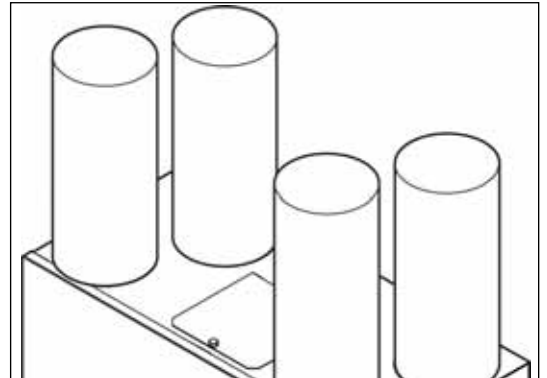
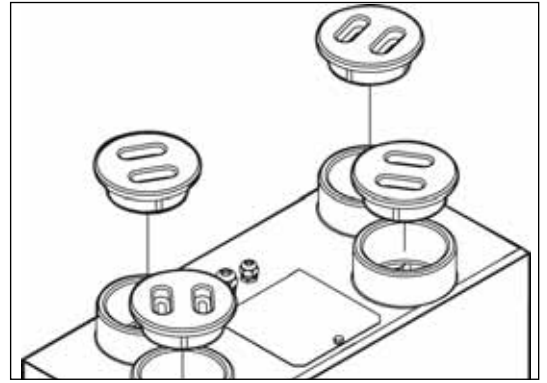

### Ducting best practice

- Ensure ducting is fitted to the correct ports
- The use of flexible ducting must be kept to a minimum and it should always be pulled taut.
- A minimum distance of 200mm between the unit and a sharp bend in duct work is recommended.
- Fire Dampers **MUST BE FITTED** to duct work at appropriate locations in accordance with Building Regulations.
- Ducting must be installed in such a way that resistance to airflow is minimised.
- Ducting terminals for "From atmosphere" and "To atmosphere" must be to the external air outside the building envelope.
- Inlet and Exhaust ducts should be separated to ensure there is no cross contamination of air (a minimum of 2m is recommended).
- Ducting in unheated spaces must always be insulated to prevent condensation forming within the ducting.
- All ducting joints including those to the unit's duct ports must be permanently sealed with ducting tape and/or silicone type sealant.
- A ducting condensate drain must be fitted to the "To atmosphere" duct work.

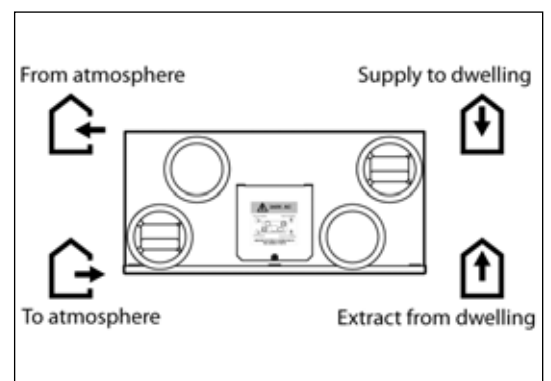

## Installation - Wiring

**WARNING: The unit MUST be earthed. All wiring must conform to current I.E.E. Wiring Regulations and all applicable standards and Building Regulations.**

- The unit is suitable for 230V~50/60Hz Single phase supply fused at 3A.
- The unit is supplied with a mains rated 3 core flexible cord (PVC sheathed, brown, blue and green/yellow 0.75mm<sup>2</sup>).
- A double pole isolation switch with contact separation of at least 3mm must be used to connect the appliance to the fixed wiring.
- Summer mode should not be connected in dwellings where open flued combustion appliances are used.
- Control switches:
  - must not be located within 1 metre of a cooker or where they may be affected by excessive heat or moisture
  - should be clearly identified and conveniently located
- The volt free boost, summer and setback switch wiring:
  - must **not** be connected to the mains supply.
  - to be connected to the control board (which is located under the access panel on the top of the unit).
  - wiring cable access is via cable glands which are suitable for 3-6mm diameter cable.
  - the boost overrun can be triggered by any device which provides a volt-free, one-way switch.
- Ensure all cable glands are tightened.
- The volt free boost switch wiring to be made by the 'Boost Switch' terminals on the control board.
- The volt free setback switch wiring connection to be made by the 'Setback Switch' terminals on the control board.
- The volt free summer mode switch wiring connection to be made by the 'Thermostat Switch' terminals on the control board

Supply Wiring Diagram

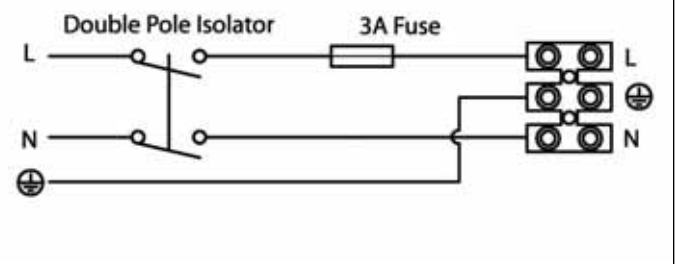

**Do not connect any mains voltage wiring to any terminal on the circuit board.**

### Setback switching and connection

Volt-free setback switching of MVHR controller PCB using single-pole latching switch and /or volt-free normally open relay contacts.

There is no limit to the number of single pole latching switches or normally open relay contacts used.

To avoid the unit being inadvertently left in Setback mode. It is recommended that only one latching switch is fitted.

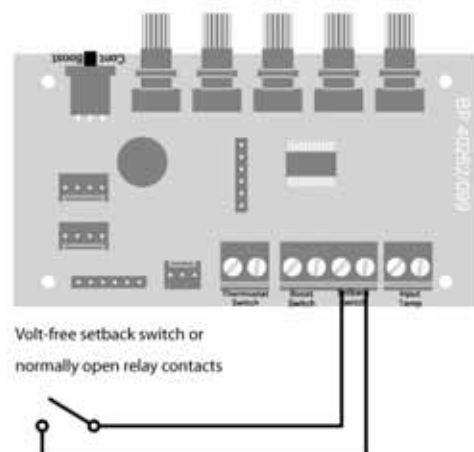

## Installation - Wiring cont

### Boost switching and connection

Volt-free boost switching of MVHR controller PCB using single-pole momentary switches and/or humidistat providing single-pole volt-free switching.

There is no limit to the number of single pole momentary switches or humidistats used (not supplied).

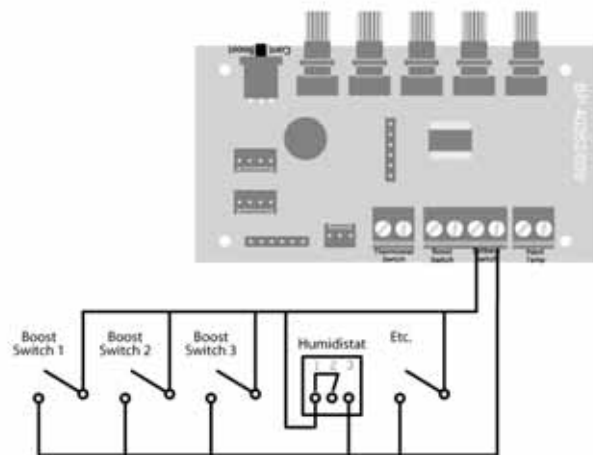

### 3 position rotary switch

#### SWITCH POSITIONS

1. Setback Speed
2. Continuous Speed
3. Boost Speed

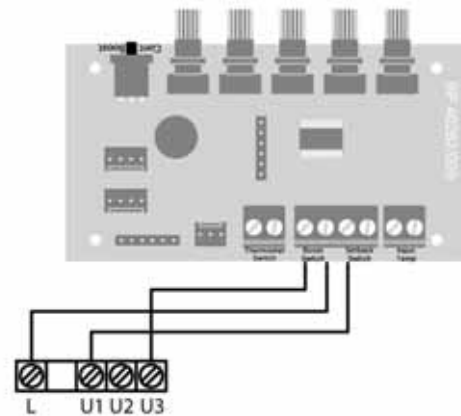

## Commissioning

### Controls

The speed of the WHHR125DC will require adjustment to ensure the flow rates achieved provide adequate ventilation in accordance with all relevant Building Regulations and applicable Standards. The WHHR125DC has 3 fan speed settings - Continuous, Boost and Setback.

The Continuous and Boost speeds are selected by placing the controller into Program mode via the Program/Run switch and changing the position of rotary potentiometers. The setback speed is set automatically, dependant on the Continuous Speed selected, at roughly half of the selected Continuous Speed.

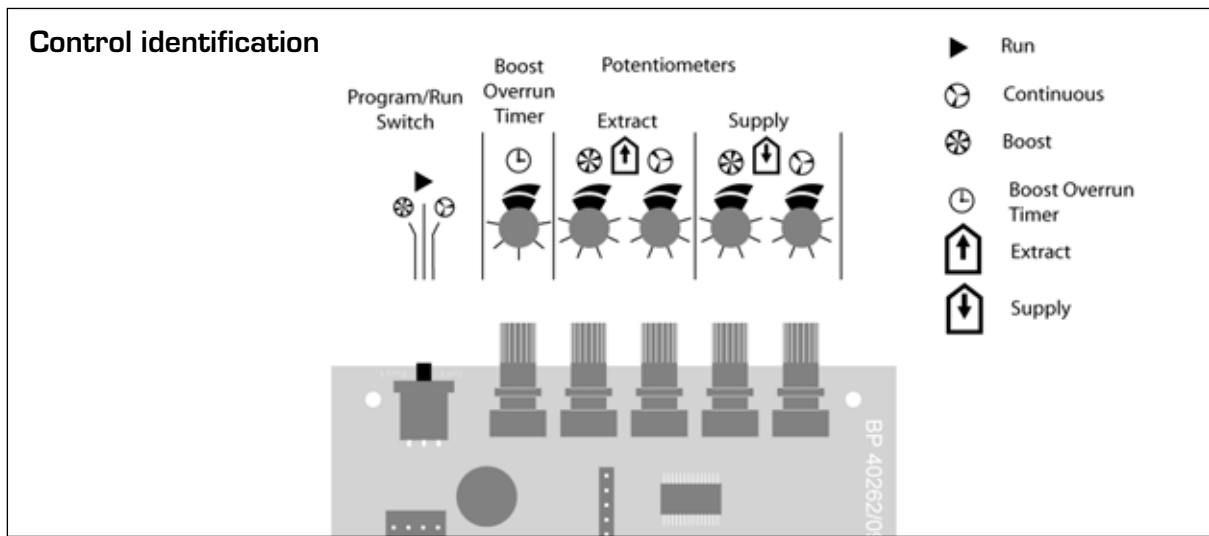

### All potentiometers

- MIN position is found by turning potentiometers fully anticlockwise.
- MAX position is 300° clockwise from the MIN position.

Prior to the first commission, set Continuous potentiometers to minimum and Boost potentiometers to maximum or reset. For procedure see page 13.

### Control Parameters

- The boost speed cannot be set lower than the continuous speed.
- The continuous speed cannot be set higher than the boost speed.
- All switching inputs are disabled when the Program/Run switch is in 'Cont' or 'Boost' positions.
- Speed control potentiometers are disabled when the Program/Run switch is in centre Run position.

Prior to the first commission, set Continuous potentiometers to minimum and Boost potentiometers to maximum or reset the controller.

### Continuous Supply and Extract Speeds

1. Move Program/Run switch to 'Cont' position
2. Rotate supply fan continuous speed adjustment potentiometer to achieve required supply continuous air flow
3. Rotate extract fan continuous speed adjustment potentiometer to achieve required extract continuous air flow
4. Return Program/Run to centre position to exit commissioning;



## Commission cont

### Boost Supply & Extract Speeds

1. Move Program/ Run switch to 'Boost' position
2. Rotate supply fan boost speed adjustment potentiometer to achieve require supply boost air flow
3. Rotate extract fan boost speed adjustment potentiometer to achieve required extract boost air flow
4. Return Program/Run to centre position to exit commissioning

### Boost Overrun Timer

Rotate overrun timer speed adjustment potentiometer to achieve required timer, Adjustment range is zero to sixty minutes. This setting can adjusted at any time.

### Setback speed

Setback speed is automatically set at the mid point between minimum possible continuous speed and the selected continuous speed.

### Summer Mode

Activating Summer Mode turns off the fan that supplies air to dwelling.

### Controller Reset

**Following a controller reset the ventilation system will need to be commissioned**

The procedure to reset the WHHR125DC controller is a simple eight step operation as follows

1. Rotate Supply Continuous speed potentiometer fully anti-clockwise
2. Rotate Supply Boost speed potentiometer fully clockwise
3. Rotate Extract Continuous speed potentiometer fully anti-clockwise
4. Rotate Extract Boost speed potentiometer fully clockwise
5. Move Run/Program switch from the Run position to the 'Cont' position
6. Move Run/Program switch from the 'Cont' position back to the Run position
7. Move Run/Program switch from the Run position to the 'Boost' position
8. Move Run/Program switch from the 'Boost' position back to the Run position

Controller reset is now complete

## Servicing & Maintenance

**WARNING:** The unit uses a 230V ~ supply and contains rotating mechanical parts.

**ISOLATE** the unit from mains power supply and allow sufficient time for all moving parts to stop before undergoing any Servicing or Maintenance.

All ventilation units require periodic maintenance. The air filters and heat exchanger of the Vectaire WHHR125DC should be cleaned regularly by a suitably qualified person (the frequency of cleaning will vary depending on the installation environment). Filters should be replaced after a maximum of 3 cleaning cycles.

### Filter and Heat Exchanger access:

1. Loosen the two corner screws located on the bottom front of the unit.

2. Remove the centre screw.

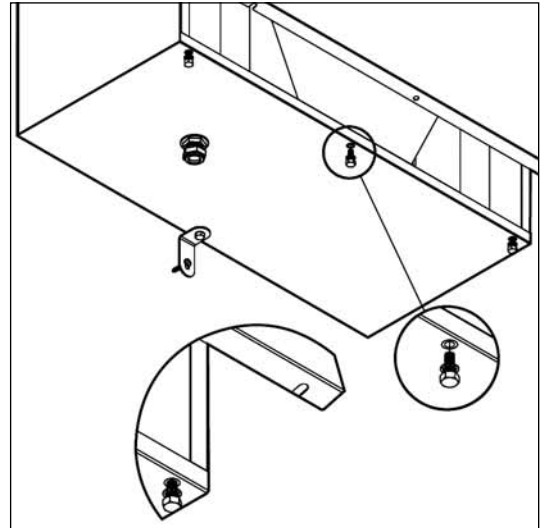

3. Completely remove the front cover by pulling it away from the unit at the bottom and lifting.

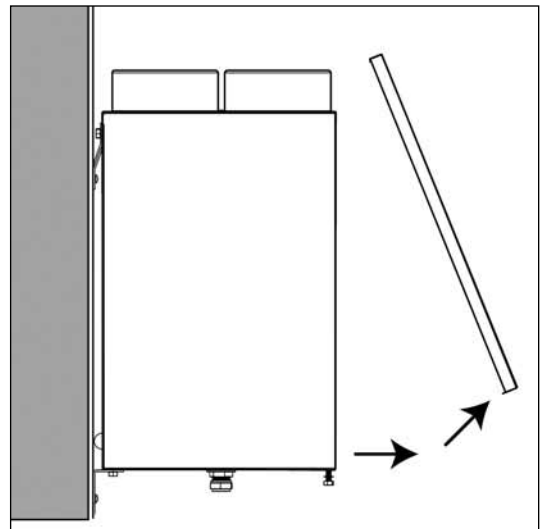

## Servicing & Maintenance cont

### Cleaning

To clean the filters and heat exchanger:

1. Remove the front cover (see page 14).
2. Slide out the filters that are fitted either side of the heat exchanger as shown.
3. Clean the filters carefully using a vacuum cleaner.
4. Carefully remove any dust from the face of the heat exchanger using a vacuum cleaner.

**Never use water or any other fluids to clean the heat exchanger.**

5. Return the heat exchanger and filters to their original position.
6. Replace the front cover and ensure it is securely located at the top before tightening all screws.
7. Power to the unit can now be restored.

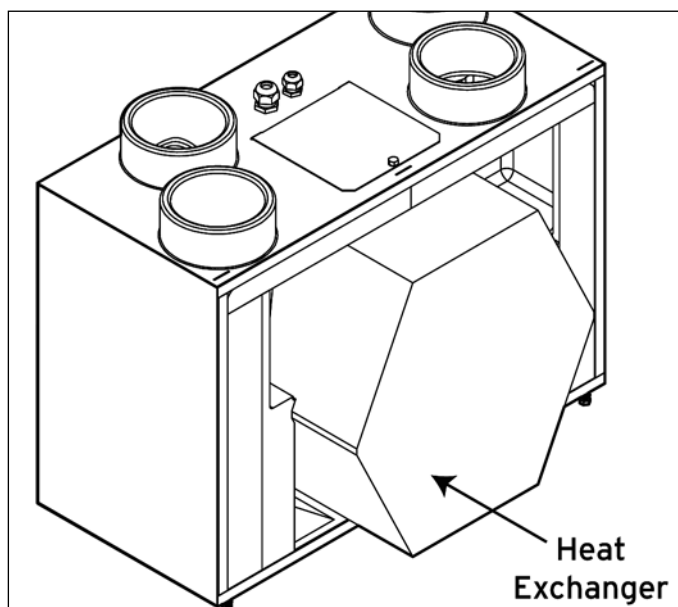
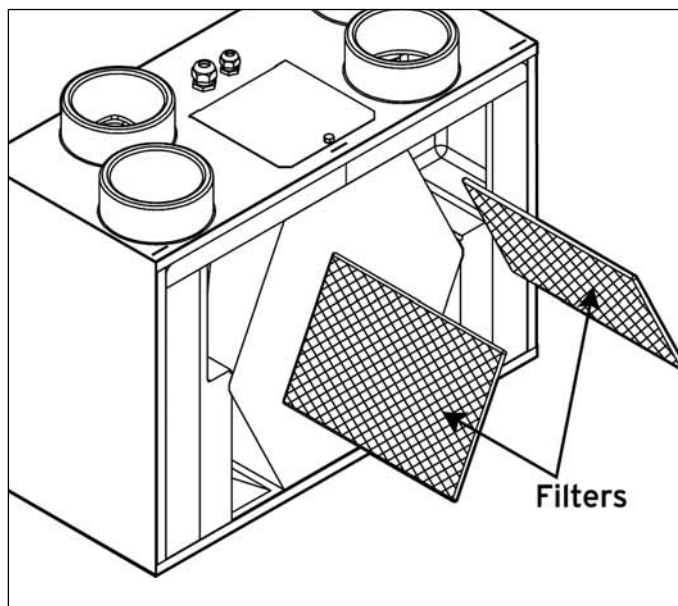

### Filter Replacement

Filters should be replaced annually or after a maximum of 3 cleaning cycles.

Replacement filters are available from Vectaire - call us on +44 (0) 1494 522333 or via [sales@vectaire.co.uk](mailto:sales@vectaire.co.uk)

### Condensate Tray

This should be checked to ensure that it is not split. If it is a replacement must be ordered and fitted.

After servicing, always complete the service record on page 16.

